

ESC SHEET PILING SOLUTIONS

PRODUCT

Cold rolled and cold formed steel pile systems engineered and manufactured to meet the specific needs of both the design engineer and the installer. A full range of standard hot rolled sheet piles, tie rods, couplers, turnbuckles, clevis plates, swivel nuts etc. can also be supplied ex international manufactures. Full design service available along with installation expertise.

All ESC cold formed and cold rolled piles are in-house custom designed and fabricated in their own facilities to recognised international standards using up-to date design software manufacturing / fabrication methodologies. Their ability to mix and match any pile system, to mix clutch types and steel grades enables them to produce the most cost effective solution for any sheet pile project.

PRODUCT STANDARDS

All ESC sheet pile systems are designed, manufactured, tested and certified to recognised international standards, typically;

- Design BS 5950 and BS EN 1993
- Manufacturing BS EN 10219, BS EN 10248 and 1 BS EN 0249
- Steel BS EN 10021, 1 BS EN 0025, ASTM A242, AS/NZ 3678
- Welding BS EN 1011, BS EN 29692, BS EN 287, BS EN 970 and BS EN 1435
- Coatings ISO 8503, ISO 12944, ISO 1461

DESIGN SERVICE

- Custom pile designs.
- Strutting, tieback and anchor designs.
- Geotechnical and slope stability analysis using REWARD and PLAXIS software.
- Design of corrosion protection systems and analysis of effective service life in corrosive environments.
- Complete CAD drawings for projects using ESC products
- Alternative designs to other forms of retaining systems, using ESC Sheet Piles.
- Feasibility studies

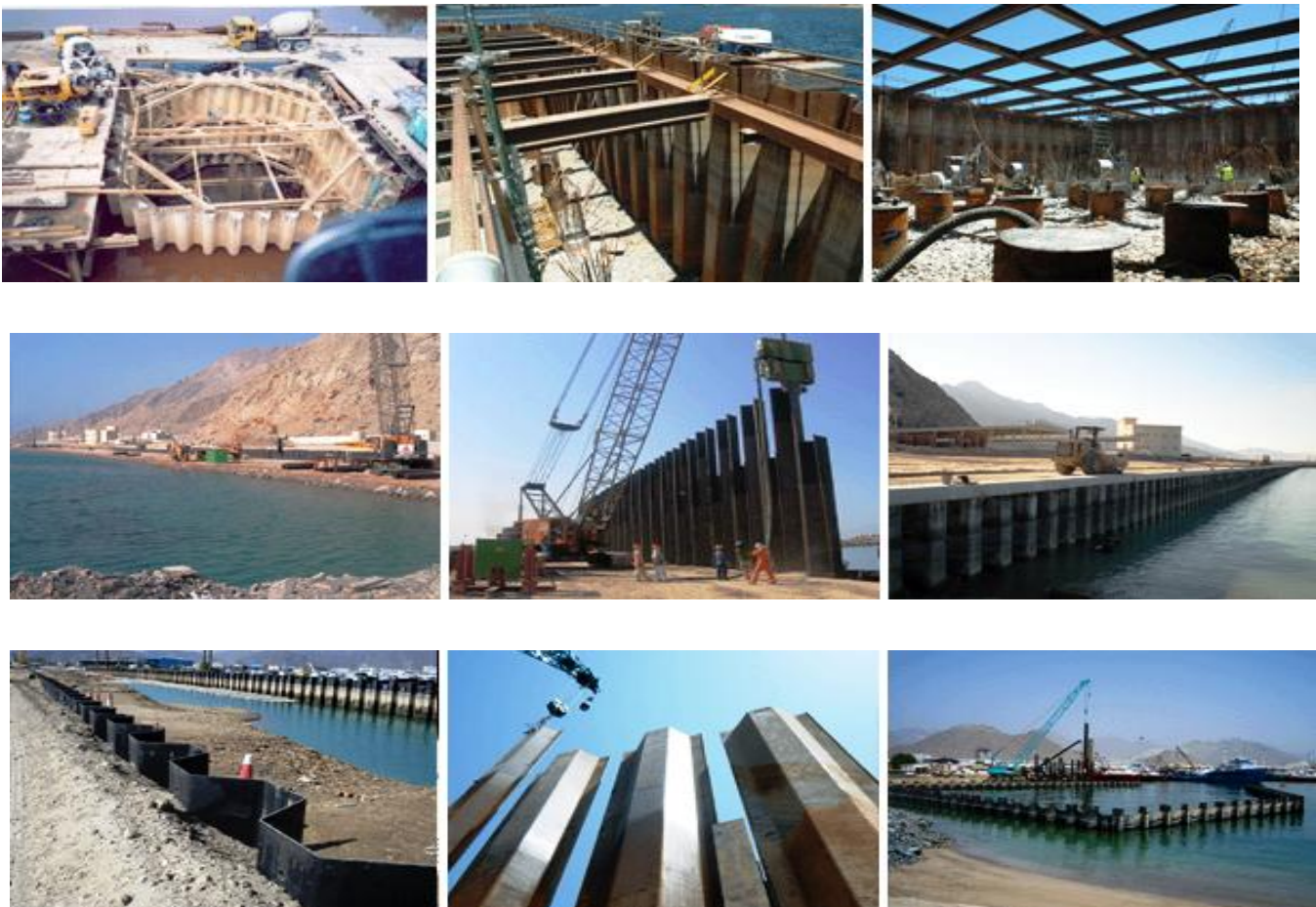

SCHEDULE OF ESC COLD FORMED PILE TYPES

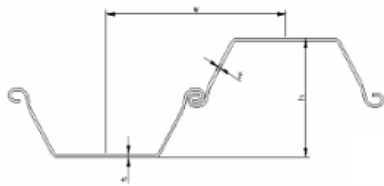

ESC - CR SHEET PILE COLD ROLLED

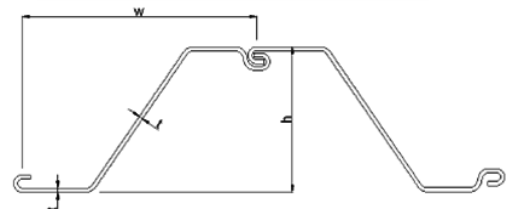

ESC - CRZ SHEET PILE COLD ROLLED

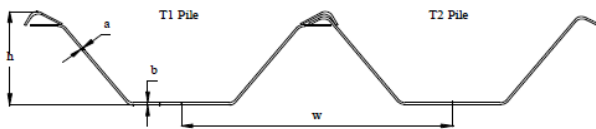

ESC - B WIDE PROFILE SHEET PILE COLD FORMED

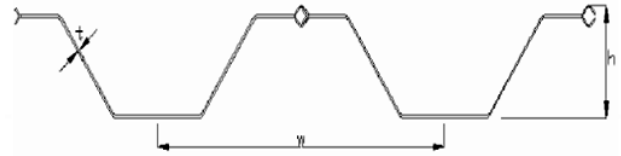

ESC - BP SHEET PILE COLD FORMED

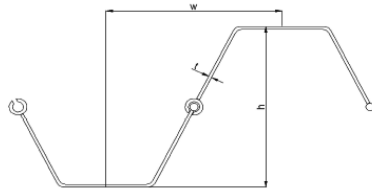

ESC - U SHEET PILE COLD FORMED

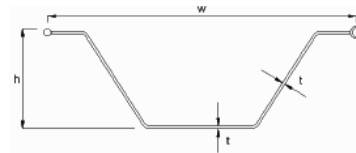

ESC - EU SHEET PILE COLD FORMED

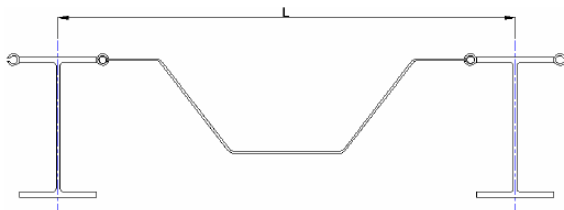

ESC - H/1 COMBINATION PILES

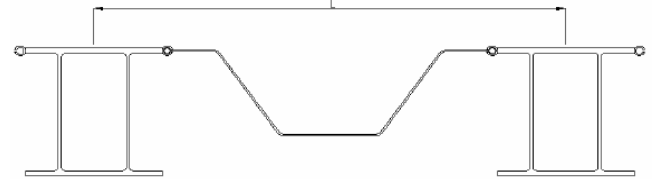

ESC - H/2 COMBINATION PILES

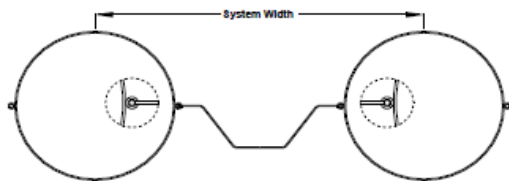

ESC - TUBULAR COMBINATION PILES

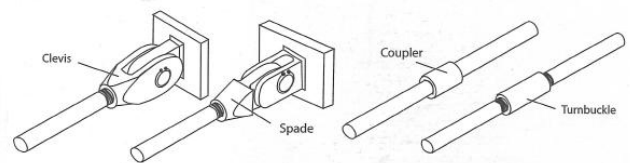

TIE RODS AND FITTINGS

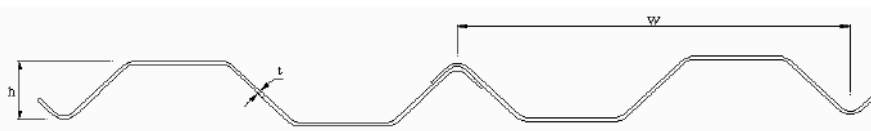

ESC - TRENCH SHEET PILE COLD FORMED

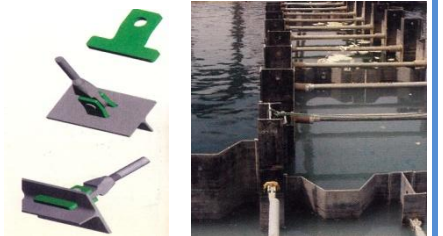

**FOR MORE DETAIL
GO TO
www.escpile.com**



Approval Certificate No: KLR 404026 Approval Certificate No: KLR 0500424

PROPERTIES OF COLD ROLLED 'U' SHEET PILES

ESC CRU Sheet Pile



Section	Dimensions			Section Area cm ² /m	Mass		Moment of Inertia cm ⁴ /m	Modulus of Section cm ³ /m
	W mm	H mm	T mm		kg/m	kg/m ²		
ESC-CRU5(600)	600	150	9.5	119.7	56.4	94	3825	510
ESC-CRU7(600)	600	340	6	98	46.2	77	11525	745
ESC-CRU8(600)	600	340	6.5	103	48.5	80.8	10835	780
ESC-CRU8(600)	600	330	7	109.6	51.6	86	12695	825
ESC-CRU8(750)	750	320	6	87.1	51.3	68.4	13118	825
ESC-CRU9(750)	750	320	7	101.74	59.9	79.9	15263	955
ESC-CRU11(600)	600	360	8	131.6	62	103.3	19903	1110
ESC-CRU12(600)	600	340	9	144.7	68.2	113.7	19230	1245
ESC-CRU14(750)	750	445	8	132	77.8	103.7	28685	1410
ESC-CRU14(600)	600	360	10	164.2	77.5	129.3	25560	1420
ESC-CRU16(400)	400	300	11	197.7	62.1	155	22590	1565
ESC-CRU17(750)	750	430	9.5	151	89.1	119	34280	1670
ESC-CRU17(500)	500	420	12	211	83	166	34900	1660
ESC-CRU18(750)	750	460	9	150.6	88.6	118	39310	1790
ESC-CRU18(600)	600	440	9	163.5	77	128	38660	1800
ESC-CRU20(750)	750	460	10	164.4	96.8	129	44450	2005
ESC-CRU21(750)	750	480	10	169.5	99.8	133	46200	2080
ESC-CRU22(600)	600	480	9.5	174	82	137	46390	2065
ESC-CRU22(600)	600	480	10	183	86.2	144	49470	2205
ESC-CRU23(750)	750	480	10.5	174	102.5	136.7	50720	2275
ESC-CRU25(750)	750	480	11.5	190	112	149	56270	2505
ESC-CRU26(750)	750	480	12	197	116	154	58200	2590
ESC-CRU28(600)	600	490	11.5	210	99	165	60600	2690
ESC-CRU32(600)	600	520	13	244	115	192	72350	3210
ESC-CRU32(750)	750	605	11	227.6	134	178.7	95269	3170
ESC-CRU35(750)	750	608	12	246.3	145	193.3	104390	3465
ESC-CRU37(750)	750	610	13	266.7	157	209.3	113590	3749
ESC-CRU40(750)	750	610	14	285.4	168	224	122879	4045
ESC-CRU43(750)	750	610	15	306	180.1	240.1	132229	4338
ESC-CRU46(750)	750	615	16	331.2	195	260	141675	4645

All sheet piles are available in Q235B, S275, S355, Q345B, Q390B and Q420B steel. Grades such as S240, S270, S320, S390, S430 and other grades can be available on request.

For assistance in selecting the correct sheet pile for your application or custom designing your own sheet pile, please contact one of our representatives. It is recommended that users refer to ESC for free assistance in correct sheet pile selection.



PROPERTIES OF COLD ROLLED 'Z' SHEET PILES

ESC CRZ Sheet Pile



Section	Width	Height	Thickness	Section Area	Weight per pile	Weight per wall	Moment of Inertia	Modulus of Section
	W	H	T					
	mm	mm	mm					
ESC-CRZ6(1450)	725	269	5.0	66.2	37.7	52	8240	612
ESC-CRZ7(1450)	725	270	6.0	79.3	45.1	62.2	9890	730
ESC-CRZ9(1614)	807	351	6.0	85.1	53.9	66.8	16989	968
ESC-CRZ12(1486)	743	407	6.0	92.4	53.9	72.5	25074	1233
ESC-CRZ12(1540)	770	344	8.5	120.0	72.6	94	21430	1245
ESC-CRZ13(1350)	675	392	6.5	70.7	55.5	82.2	27251	1370
ESC-CRZ14(1350)	675	392	7.0	76.1	59.7	88.5	29281	1470
ESC-CRZ14(1540)	770	345	9.5	132.0	79.5	103	23300	1355
ESC-CRZ14(1486)	743	408	7.0	107.4	62.6	84.3	29179	1432
ESC-CRZ16(1488)	744	409	8.0	136.5	71.4	96	28010	1628
ESC-CRZ18(1370)	685	392	9.0	97.6	76.6	111.8	37580	1880
ESC-CRZ18(1400)	700	420	9.0	147.8	81.2	116	38866	1843
ESC-CRZ20(1370)	685	392	10.0	108.4	85.1	124.2	41601	2070
ESC-CRZ22(1300)	650	429	9	101.1	79.4	122.1	48521	2220
ESC-CRZ24(1400)	700	459	11.2	174	95.7	137	55820	2430
ESC-CRZ26(1400)	700	460	12.2	187	112.3	160.4	68689	2986
ESC-CRZ28(1400)	700	461	13.2	200	110	157	63620	2760
ESC-CRZ32(1350)	675	476	11	138	108.3	160.5	77367	3180
ESC-CRZ34(1350)	675	550	11.5	211.7	112.2	166.2	82955	3425
ESC-CRZ37(1400)	700	560	12.5	226	124.5	177.8	92415	3710
ESC-CRZ38(1400)	700	500	14	246	135	192.8	96657	3805
ESC-CRZ41(1400)	700	560	14	254	139.6	199	102630	4095
ESC-CRZ48(1160)	580	500	15.5	305.3	139	239.7	115678	4800
ESC-CRZ50(1160)	580	520	15.5	317.4	144.5	249.2	129443	5000

All sheet piles are available in Q235B, S275, S355, Q345B, Q390B and Q420B steel. Grades such as S240, S270, S320, S390, S430 and other grades can be available on request.

For assistance in selecting the correct sheet pile for your application or custom designing your own sheet pile, please contact one of our representatives. It is recommended that users refer to ESC for free assistance in correct sheet pile selection.



ESC / MARUBENI ITOCHU STEEL : JAPAN



Hot Rolled Sheet Pile

Range 2011

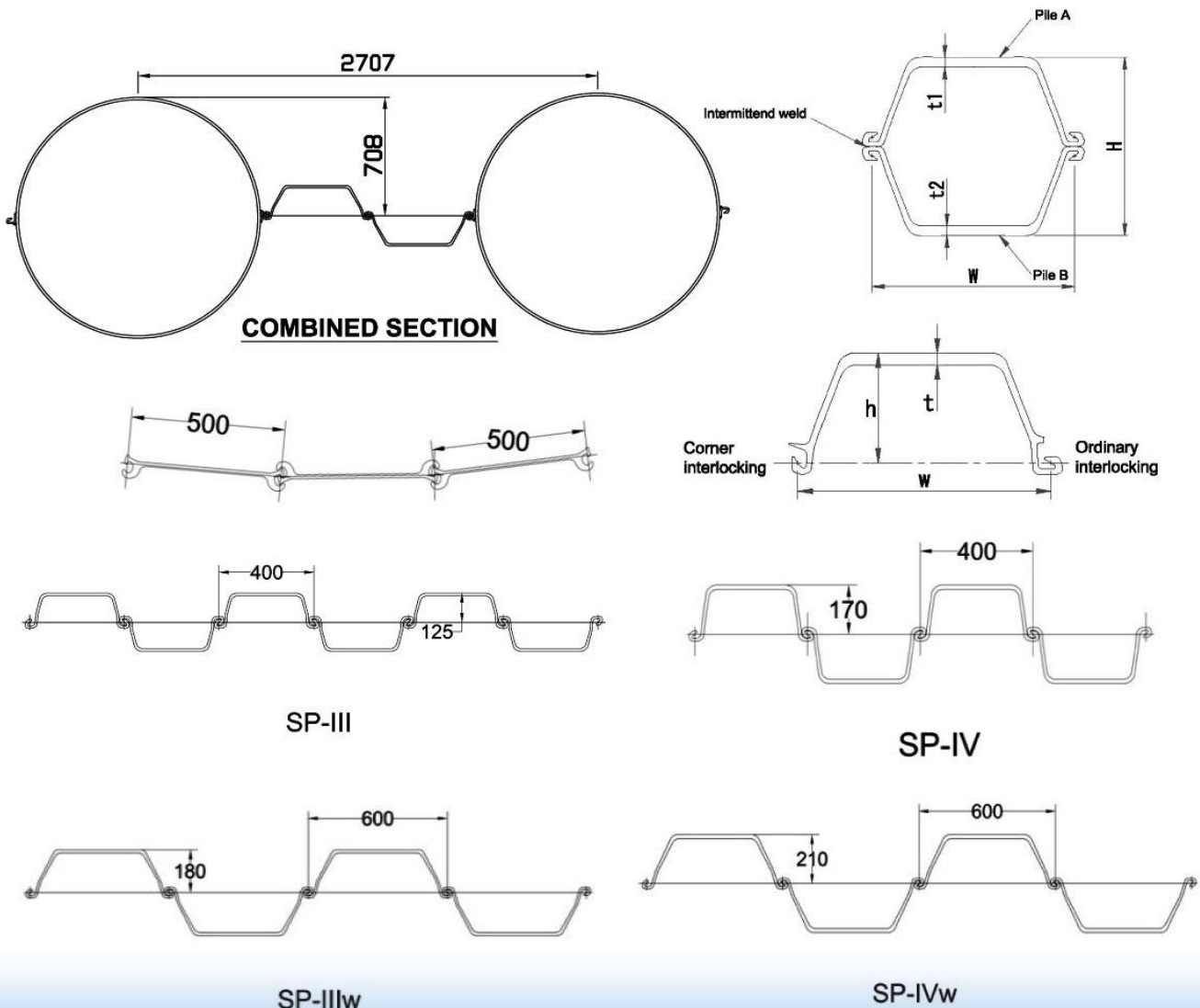

COLD FORMED STRUCTURAL STEEL PROFILES

MANUFACTURED TO AS/NZS1163-2009 & EN10219:2006

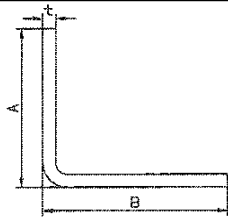

A	B	t
85-300	20-800	4-16

L - BEAM

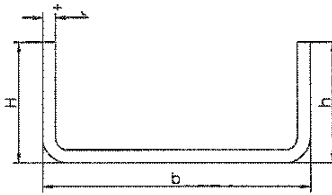

b	H	h	t
60-500	10-250	10-250	4-16

U - BEAM

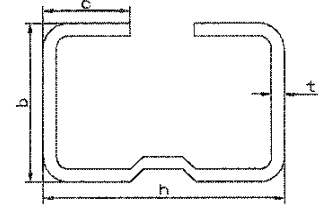

h	b	c	t
50-600	80-250	10-50	4-12

INTERNAL CRIMPING EDGES U - BEAM

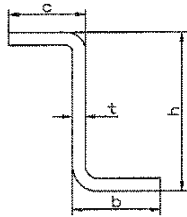

h	b	c	t
80-400	40-200	40-200	4-12

Z - BEAM

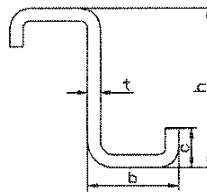

h	b	c	t
60-400	20-250	10-50	1.5-8

CRIMPING EDGES Z - BEAM

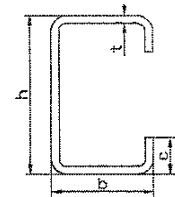

h	b	c	t
30-800	20-180	10-50	1-12

INTERNAL CRIMPING EDGES C-BEAM

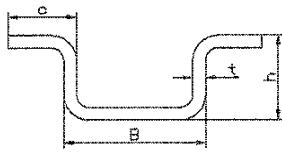

B	h	c	t
30-600	20-250	10-50	1.5-8

EXTERNAL CRIMPING EDGES U - BEAM

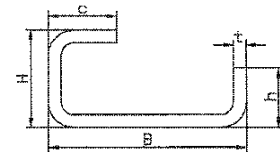
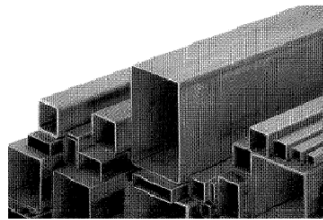

B	H	c	h	t
30-600	20-250	10-50	20-250	1.5-8

SINGLE INTERNAL CRIMPING EDGES U - BEAM

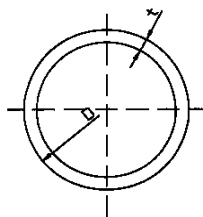

D	t
25-400	1-12

CIRCULAR TUBE

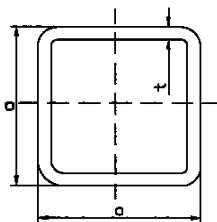

a	t
50-300	1-12

SQUARE TUBE

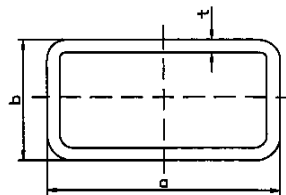

a	b	t
80-300	80-300	1-12

RECTANGLE TUBE

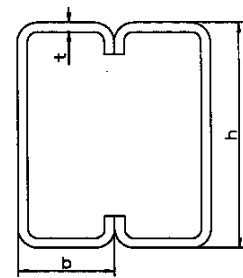

h	b	t
30-600	20-180	1-12

FACE-TO-FACE WELDED C-BEAM

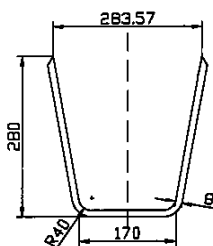

U-BEAM

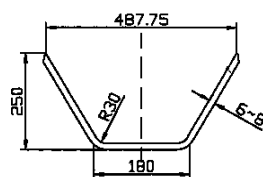

U-BEAM

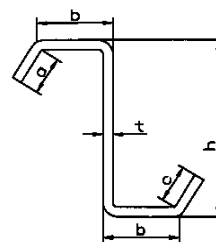

h	b	c	t
30-600	20-180	10-50	1-12

BEVELED Z-BEAM

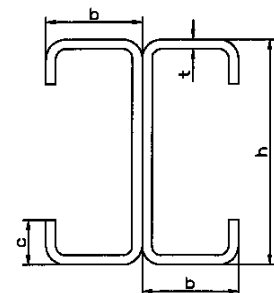

h	b	c	t
30-600	20-180	10-50	1-12

BACK-TO-BACK WELDED C-BEAM

Ohau Channel / Lake Rotoiti Diversion Wall, Rotorua, New Zealand.

Project Description

Environment Bay of Plenty was granted resource consent to build the diversion wall structure in Lake Rotoiti. The Diversion Wall is designed to stop water flowing from Lake Rotorua into the main body of Lake Rotoiti, instead diverting it down the Kaituna River via the Ohau Channel

Most of Lake Rotoiti's problems are caused by nutrients flowing into it from Lake Rotorua. So the diversion wall will, over time, significantly improve the lake's water quality. The Ohau Channel Diversion Wall is located at the outlet of the Ohau Channel, which links Lake Rotorua and Lake Rotoiti. It is 1275 metres long and diverts the water from Lake Rotorua, with its higher nutrient levels, directly down the Kaituna River, preventing it from degrading Lake Rotoiti's water quality.



Geotech Systems Ltd and Ground Engineering Ltd (a related company) worked very closely with ESC and the Contractor (HEB Smithbridge Ltd) to provide the most practical and economical solution for this prestigious project.

The materials were all manufactured in ESC's China factory and delivered over the course of 2007.

ESC designed / manufactured a custom wall system based on king post H piles at 3.2 metre centres and infill sheet piles.

The design was a reconfiguration of the sheet pile wall as designed by the project's design consultants BECA.

All the final designs and calculations were carried out by ESC in conjunction with the project consultants and the Contractor.

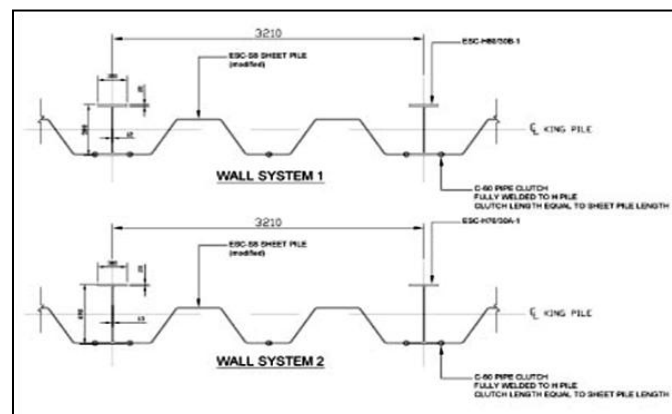

ESC's custom sheet pile designed specifically for this project



ESC's custom sheet pile designed specifically for this project

SHEET PILE COMPONENTS DELIVERED TO OHAU CHANNEL DIVERSION	
ESC H60/30A-1 (with clutches)	655.27 tons
ESC H70/30A-1 (with clutches)	234.52 tons
ESC S8 Sheet Piles (modified)	875.83 tons
ESC H60/30A-1 (without clutches)	452.47 tons
ESC H60/30A-1 (without clutches)	419.18 tons

In terms of engineering, the wall was unique in that the engineer required a guaranteed zero settlement, even with NZ's high seismic activity. The H pile wall solution was therefore employed because the H piles could be driven through the deep soft lakebed mud and down onto the bedrock. In some cases, this meant H piles over 50m in length, which had to be extended during driving until the required set was achieved.

The diversion wall is driven into Rotoiti's lake bed and rises to just above lake level. There is a cap on top of the wall to discourage people from walking on it and for safety reasons.

The final design of the structure was based on feedback from the public at various hui (Maori Assembly) and public meetings, as well as comments received on the questionnaires, and a number of technical studies. These studies include:

- Water quality modelling
- Sediment transport modelling
- Hydrodynamic modelling of the lake
- Geotechnical investigations
- Assessment of effects on downstream water quality in the Kaituna River and Maketu Estuary
- Landscape and visual assessment
- Cultural assessment
- Ecological assessment, including effects on fish and water birds

The installed wall cost just under NZ\$10 million and was funded by Environment Bay of Plenty and Central Government and is expected to improve Lake Rotoiti's water quality in less than five years, in conjunction with lakeside sewerage reticulation projects.

The wall will divert water currently flowing through the channel from Lake Rotorua into Lake Rotoiti, directly down the Kaituna River. Currently, about 40 percent of this water flows into the Kaituna River, mostly in summer, the rest of the year it flows mostly into Lake Rotoiti.

The diversion will prevent 180 tonnes of nitrogen and 15 tonnes of phosphorus entering the main body of Lake Rotoiti from Lake Rotorua each year through the Ohau Channel. The diversion is expected to improve Lake Rotoiti's water quality within five years, as research has shown that 70 per cent of the nutrients entering the lake come through the Ohau Channel. It is not expected to have any significant impact on Kaituna River quality.

A five knot boat speed by 50 metre wide channel on the western side of the diversion wall allows boat access to and from Lake Rotoiti and the Ohau Channel and an exclusion zone at the lake edge protects birdlife.

The wall was part of a number of initiatives being used to help protect and restore the lakes, for example, structural interventions like the wall through to land use management practices to reduce nutrients leaching from farm land. The effect of the wall is now being closely monitored to assess its success and whether wildlife is adversely affected by it or not, including a five-year fisheries monitoring programme.